

Description:

The ESC1 EGO Signal Conditioner alters the signal from EGO sensors under boost conditions. It may be used in either single or dual EGO sensor applications. Under vacuum conditions it outputs a signal which is identical to the EGO signals that appear at the input. Under boost, it outputs an internally generated signal to allow open loop operation.

The ESC1 is especially useful for forced induction conversions where a supercharger or turbocharger is fitted to an engine which is normally naturally aspirated. In the vacuum region of operation the ECU operates in its normal closed loop mode of operation. Under boost, the ECU transitions into an open loop mode and maintains its internal mapping tables.

The ESC1 allows the conversion to forced induction on engines with modern fuel injection including those with OBDII on-board diagnostics. The stock ECU programming may be used without activation of fault codes under boost.

Features:

- Dual channels condition the signals for one or two EGO sensors
- Internal MAP sensor
- May be internally calibrated for manifold pressure activation point
- Compatible with OBDII systems
- Versions available for 1V and 5V range EGO sensors

Typical Connections:

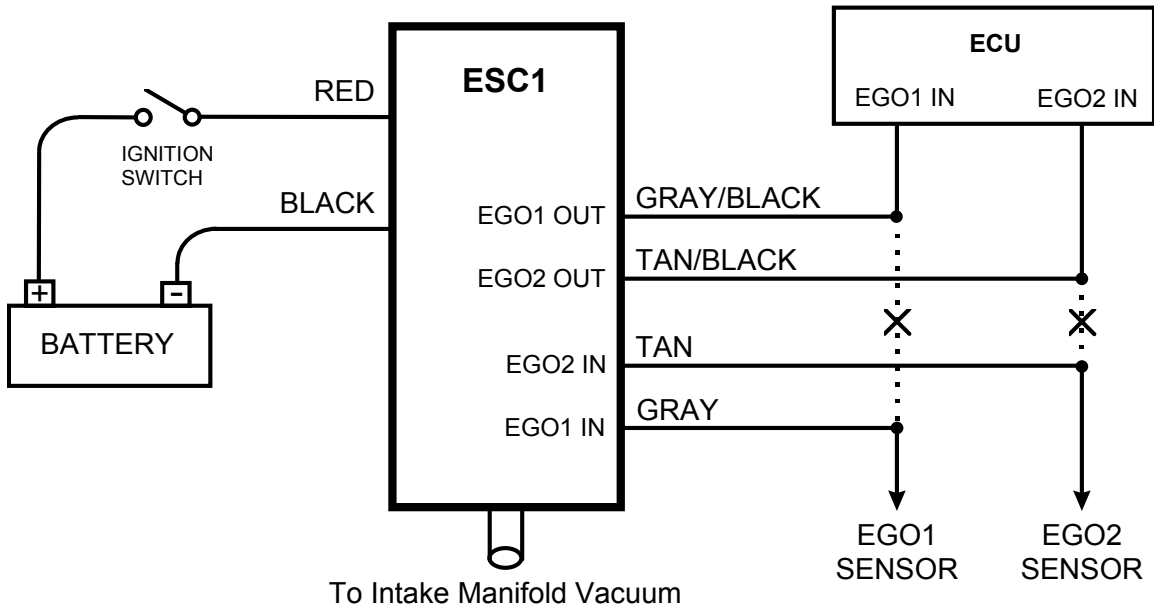

Wire Assignments:

WIRE COLOR	LABEL	CONNECT TO
Red	BATT +	Switched battery positive (+12V)
Black	BATT -	Battery negative (chassis ground)
Gray	EGO1 IN	EGO1 sensor output
Tan	EGO2 IN	EGO2 sensor output
Gray/Black	EGO1 OUT	EGO1 ECU Input
Tan/Black	EGO2 OUT	EGO2 ECU Input

Electrical Characteristics:

PARAMETER	CONDITIONS	MIN	TYP	MAX	UNITS
Supply Voltage	BATT+ to BATT-	10	13.5	16	V
Input Voltage	EGO1 In, EGO2 In	0		7	V
Input Resistance	EGO1 In, EGO2 In	1			MΩ
Output Resistance	EGO1Out, EGO2 Out		100		Ω
Supply Current	BATT+ To BATT-		36		mA

Mechanical Characteristics:

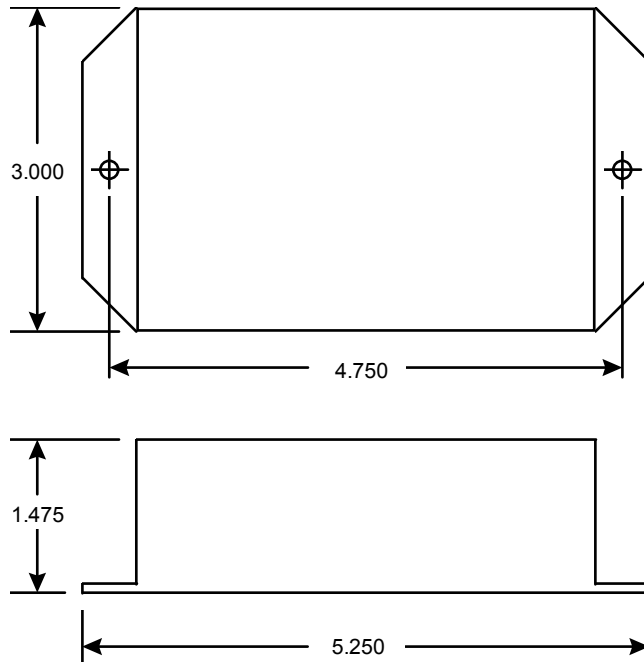

1949 E. Deere Ave.
Santa Ana, CA 92705
TEL (949) 863-1359
FAX (949) 863-1363