**ARM1_5-0****Description:**

The ARM1 is a precision, miniature instrument that provides an easy to read, real time indication of the air/fuel ratio of an internal combustion engine. It may be used with either an existing or dedicated EGO (Exhaust Gas Oxygen) sensor. High impedance, precision circuitry is used to avoid loading the output of the EGO sensor while rejecting noise and preserving accuracy.

The output of the ARM1 is a 10 segment, 5 color LED display. The use of color makes the meter readable with peripheral vision. It is calibrated for a 5V full scale input range and sensitivity of 0.5V per display segment.

The ARM1 is particularly useful with modified engines to assure proper air/fuel ratio. It is an ideal monitoring tool when calibrating engine air/fuel ratio or making adjustments while driving. The ARM1_5-0 is specifically designed for use with oxygen sensors that produce a 5V output range where 5V corresponds to a lean reading and 0V corresponds to rich.

Features:

- Five color display can be read with peripheral vision
- Dimming feature automatically reduces brightness at night
- Miniature size allows wide range of installation options
- Differential inputs reject induced noise and preserve accuracy
- Signal filtering enhances readability of the display
- High input impedance does not effect operation of the EGO sensor
- Battery reversal protection

Typical Connections:

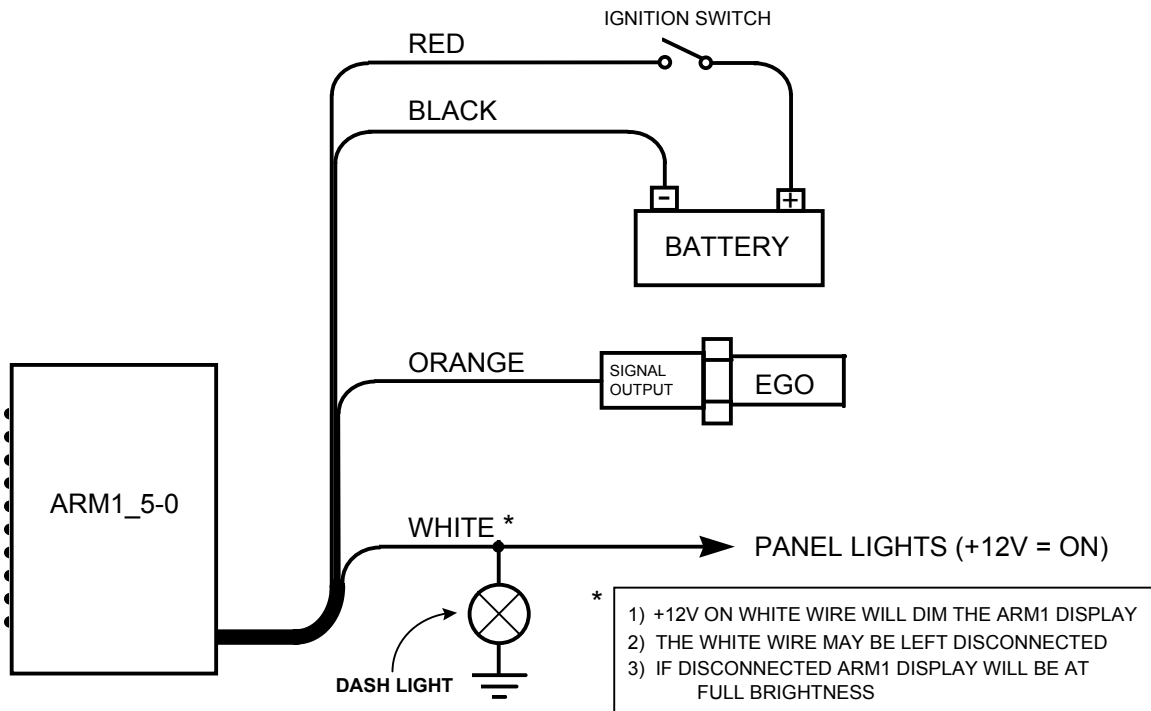

Wire Assignments:

LABEL	CONNECT TO	WIRE COLOR
BATT +	Battery positive (+12V)	Red
BATT -	Battery negative (chassis ground)	Black
EGO +	EGO sensor output	Orange
LIGHT	Instrument panel lighting (+12V = ON)	White

Typical Display Characteristics:

LED	COLOR	MIN (V)	MAX (V)	A/F RATIO *	λ *
1	RED	4.5	5.0	17.0:1	1.16
2	RED	4.0	4.5	16.0:1	1.09
3	ORANGE	3.5	4.0	15.5:1	1.05
4	ORANGE	3.0	3.5	15.0:1	1.02
5	YELLOW	2.5	3.0	14.7:1	1
6	YELLOW	2.0	2.5	14.6:1	0.99
7	GREEN	1.5	2.0	14.5:1	0.99
8	GREEN	1.0	1.5	14.2:1	0.97
9	BLUE	0.5	1.0	13.2:1	0.90
10	BLUE	0	0.5	12.5:1	0.85

How To Interpret The Display:

The segment illuminated indicates the instantaneous air/fuel ratio of the engine. The exact air/fuel ratio is a function of the particular EGO sensor that is used. The ARM1_5-0 is designed to work with oxygen sensors that operate from 5V to 0V. EGO sensors must be up to their normal operating temperature before they produce valid readings. After an engine runs for few minutes, its hot exhaust gas will appropriately elevate the temperature of the EGO sensor. A heated sensor will provide valid readings more quickly.

Most EGO sensors will indicate a stoichiometric air/fuel ratio of 14.7:1 with an output voltage of approximately 2.5V to 3V. This corresponds to the fifth segment of the display which is the lower of the two yellow segments. In general terms, yellow indicates a near stoichiometric condition. At this operating point, the engine is mixing the proper ratio of air and fuel for complete combustion. This is the operating point for optimum driveability and economy as well as minimum emissions.

When a green segment is illuminated, the engine is running in a rich condition. A rich air/fuel ratio is associated with values less than 14.7:1. Rich operation corresponds to higher output power, lower fuel economy and higher emissions of carbon monoxide and hydrocarbons.

Blue segments indicate a very rich condition. A very rich mixture should only occur under hard acceleration.

Orange segments indicate a lean condition. Lean operation is associated with improved fuel economy and higher emissions of oxides of nitrogen. Lean operation is suited for light load cruise and coast down conditions.

Red segments indicate a very lean condition. Very lean operation must be avoided when the engine is under load. Such operation results in fuel starvation and higher engine temperatures.

In closed loop applications, when the engine is operating near the stoichiometric point, the ECU continuously adjusts the air/fuel ratio. As a result, the display will cycle, or dither, above and below the stoichiometric point typically at a rate of about once per second. Such cycling indicates that the ECU is able to dial in the correct air/fuel ratio.

Electrical Characteristics:

PARAMETER	CONDITIONS	MIN	TYP	MAX	UNITS
Supply Voltage	BATT+ to BATT-	10	13.5	16	V
Input Voltage	EGOI+ to EGOI-	0		5	V
Dimming Voltage	LIGHT to BATT-	2	13.5	16	V
Input Resistance	EGOI+	1.8			MΩ
Supply Current	BATT+ terminal (day)		40		mA
Supply Current	BATT+ terminal (night)		10		mA

Mechanical Characteristics:

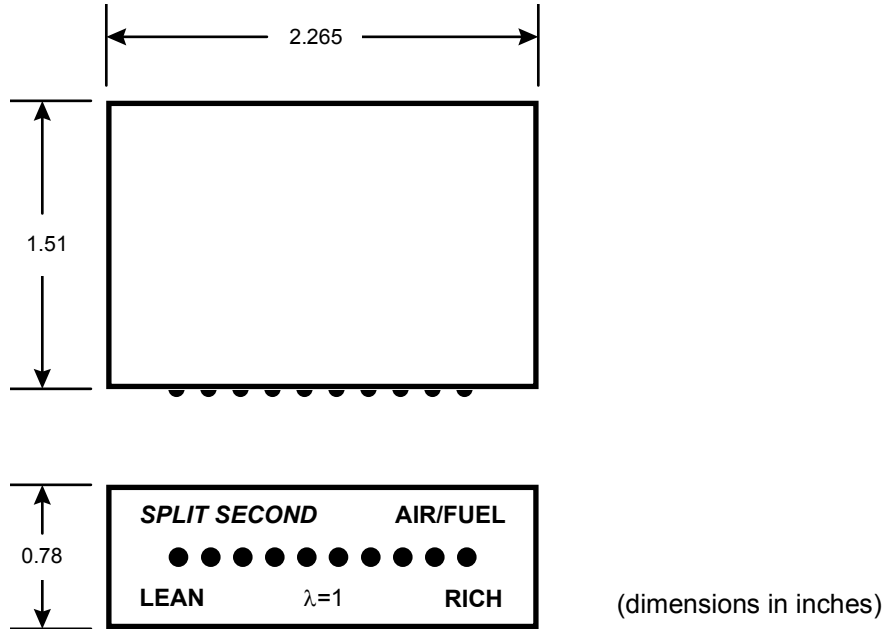

1949 E. Deere Ave.
 Santa Ana, CA 92705
 TEL (949) 863-1359
 FAX (949) 863-1363