



AIC1 Additional Injector Controller

Description:

The AIC1 Additional Injector Controller provides precise fuel delivery over the boosted operating range of an internal combustion engine. It is designed for use with engines that have been converted to forced induction with the addition of turbochargers or superchargers. The AIC1 gives the user a convenient way to set the fuel mixture for proper air/fuel ratio in the boost region.

The AIC1 is a stand alone additional injector controller. It provides three dimensional mapping of additional fuel. Injector pulse width is loaded directly into cell locations on a map defined by boost pressure and RPM. Two independent maps can control up to four injectors. Map A can drive two low or high impedance injectors. Map B can drive two high impedance injectors.

The calibration of the AIC1 is done through a serial interface, which is active while in operation. The AIC1 is programmed with a Windows 95/98 program called R4. The software provides real time display of RPM, manifold pressure, injector on time and duty cycle in percent. A variety of editing tools ease the task of setting up an initial map and quickly fine tuning for optimum performance.

The AIC1 can be order in a variety of configurations. Refer to the ordering information section to see the combination of pressures sensors, number of injectors and injector types that are available. Both absolute and gauge pressure sensors are available. The absolute sensor can read both vacuum and pressure regions and is used to fire the injectors in the vacuum region or when elevation compensation is desired. A gauge pressure sensor reads in the boost region only. In some applications, the gauge pressure sensor can cause an excessively rich fuel mixture at high elevations.

The AIC1 is typically used in conjunction with a precision air/fuel ratio meter such as the Split Second ARM1. The air/fuel ratio meter provides the required information needed to properly set the AIC1 fuel program.

Features:

- Stand alone device
- Two three-dimensional map tables defined by boost pressure and RPM
- Compatible with 2 and 4 stroke engines from 1 to 12 cylinders
- Laptop adjustable
- Programmed directly according to pulse width in milliseconds
- Can be mounted in the engine compartment
- Internal MAP sensor
- Transient surge and battery reversal protection

Typical Connections:

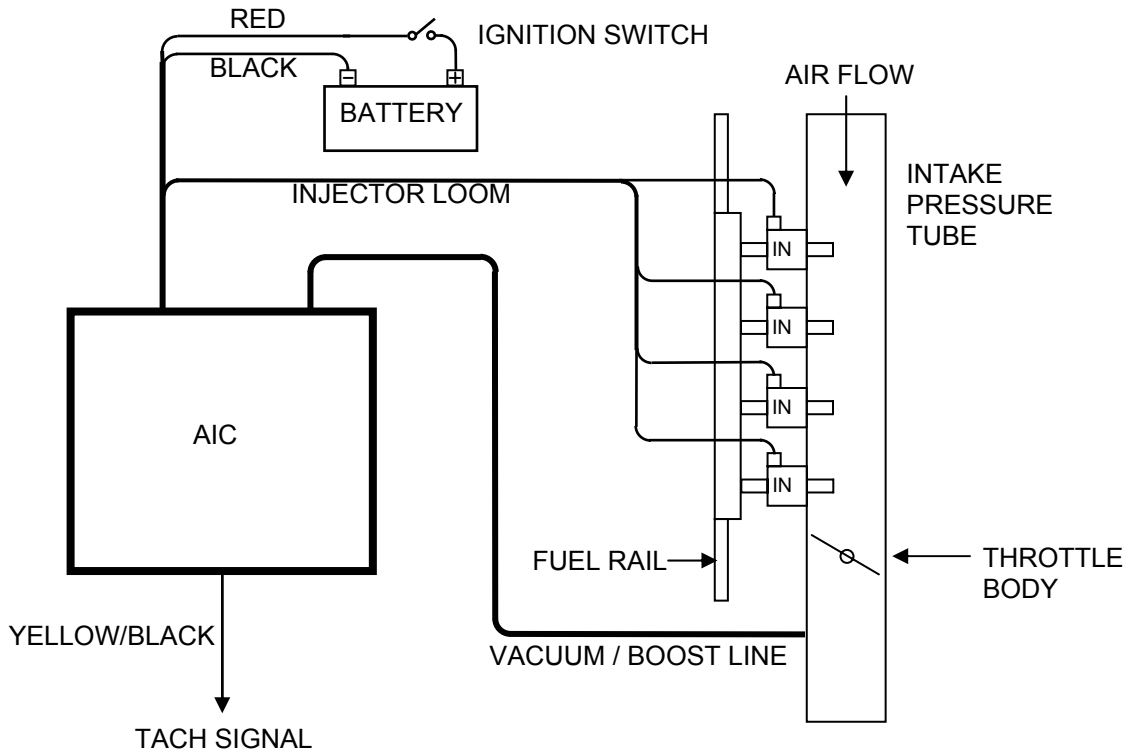

Typical Wire Assignments:

LABEL	CONNECT TO	MAP TABLE	WIRE COLOR
BATT+	Battery positive (+12V)		Red
BATT-	Battery negative (chassis ground)		Black
INJA+	Injector plug positive (+12V)	A	Red (2)
INJA-	Injector plug negative (injector driver)		Tan (2)
INJB+	Injector plug positive (+12V)	B	Red (2)
INJB-	Injector plug negative (injector driver)		Tan/Black (2)
TACH	Tach signal (pulses per rev = #cyl/2)		Yellow/Black
F-DB9	Serial connector on computer		-

Software:

The AIC1 is programmed with the R4 Fuel Controller Software. When the software is launched an identification screen will appear that says Split Second. After four seconds, the main menu will appear. If this is a new application, select **File** then **New Customer** to create a new customer. Type in the customer name and save. The default location for customer names is My Documents. When you return to the main screen, select **File** and **Open Customer** to open the customer file that you just created. Once the customer is open, the **Maps**, **View**, **Options** and **Help** tabs become active. Whenever you write new data to the AIC1, all settings and mapping will automatically be saved under the current customer name. You can fill in the various fields such as name, address etc. if you like.

Connections:

Select the proper com port for the serial connector on your computer. Remove the lid on the AIC1. Connect the AIC1 to the computer using a 9-pin serial cable. The cable must have a male plug on one end and a female on the other. Once the serial cable is plugged in and the AIC1 is powered up, you may connect to the AIC1 by selecting the **Connect to ECU** icon. Once communication has been established with the ECU, the **Real Time** pull down becomes active.

There are two map tables that can be used. Table A drives the injectors controlled by the Tan wires. These injectors can be either low or high impedance. Table B drives the injectors controlled by the Tan/Black wires. These can only be high impedance.

Programming:

Use the **Options** pull down and **Engine Settings** to select the number of cylinders of the engine. Use **Options** and **System Settings** to select Additional Injector Controller and the correct pressure reading. If you have a gauge pressure sensor, select gauge pressure. If you have an absolute sensor, select either absolute pressure or vacuum/pressure.

Use the **Maps** pull down to access the fuel map tables. The numbers entered into the cells on the map represent the injector on time in milliseconds. Whenever a cell is highlighted, the injector pulse width is shown in the upper left hand corner of the table.

You can click and drag to highlight an area of cells. Once highlighted, you can use the icons across the top of the window to fill all the selected cells with a value. For example, if you fill the selected cells with the value 10, whenever the manifold pressure and RPM match one of those cell locations, the injectors will be pulsed for 10 milliseconds.

A highlighted area of cells can also be changed by a percentage by using the **Change By** button. To increase a highlighted area of cells by 10 percent for example, select the cells, click on the **Change By** button and enter 10. To reduce by 50 percent, enter -50.

You can also fill a range of cells with values that are interpolated from the end points. This works over a row, column or 2-dimensional area. To fill values over a two dimensional area, fill the four corners of the area with cell values. Then click and drag to select the area encompassed by those corner cells. Click on the **Auto Fill** button. The software will calculate and fill the correct values for all highlighted cells.

If you are using table B as well as A, you will have to fill those values also. If you want to use the same values in tables A and B, you can copy and paste the data. Hit the **Select All** button while in the table you want to copy. Then press the **Copy** button. Go to the other map table and highlight the cell in the upper left hand corner of the table. Then press the **Paste** button.

Once the maps are set up, you can write to the ECU in the AIC1. To write to the ECU, the ignition must be on so that the AIC1 is powered up. The engine must be off so that tach pulses are not present during programming. To write to the ECU press the **Write Data to the ECU** button. The operation of writing the data will also save the configuration and map information in the current file that is open. You can also upload from the ECU using the **Read Data From the ECU** button. You can then save or modify the data.

Operation:

Once the data is loaded into the AIC1, the engine can be started. From the main screen, the **Real Time** pull down can be used to observe a variety of operating parameters. The **All** option brings up a window that displays boost pressure and RPM as well as pulse width and duty cycle for both A and B injectors. The All window can be enlarged to full screen size to make it easy to read while working on the engine. The **RPM** and **Pressure** options display analog gauges that show those parameters. The **All**, **RPM** and **Pressure** options can all be displayed simultaneously.

Ordering Options:

Part Number	Number of Injectors	Injector Impedance	MAP Sensor Type	Map Tables Used
AIC1-A2H	2	High	Absolute	A
AIC1-A4H	4	High	Absolute	A and B
AIC1-G2H	2	High	Gauge	A
AIC1-G4H	4	High	Gauge	A and B
AIC1-A1L	1	Low	Absolute	A
AIC1-A2L	2	Low	Absolute	A
AIC1-G1L	1	Low	Gauge	A
AIC1-G2L	2	Low	Gauge	A

Electrical Characteristics:

PARAMETER	CONDITIONS	MIN	TYP	MAX	UNITS
Supply Voltage	BATT+ to BATT-	12	13.5	15	V
Supply Current	Into BATT+ terminal		16		mA
Tach threshold	Normal operation		1.6		V
Tach Hysteresis	Normal operation		0.5		V
Boost Range	On vacuum/boost hose	0		25.5	PSI
A Injector peak	Initial sink current		4		A
A Injector hold	Steady state sink current		1		A
B Injector limit	Max current before shutdown		2		A

Mechanical Characteristics:

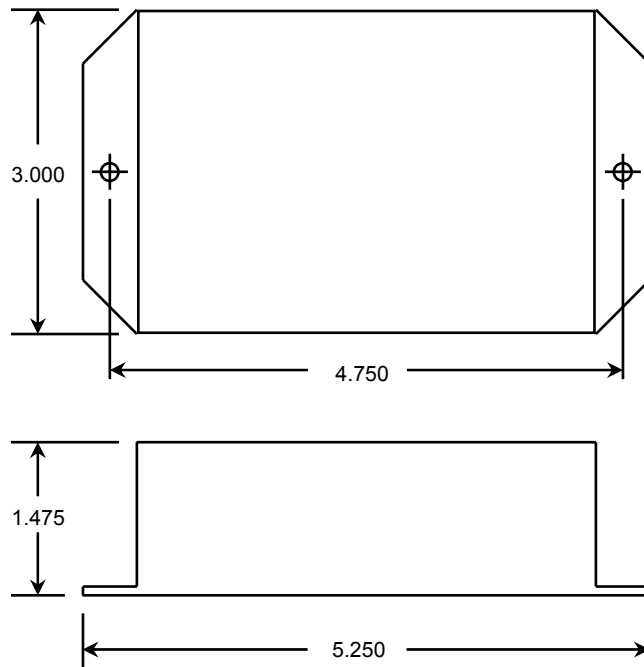

1949 E. Deere Ave.
 Santa Ana, CA 92705
 TEL (949) 863-1359
 FAX (949) 863-1363