



PSC1-005 Programmable Signal Calibrator

Description:

The PSC1-005 Programmable Signal Calibrator is designed specifically to perform an air flow meter (AFM) to mass air flow (MAF) conversion on vehicles that use an AFM with an inverted output. Such AFMs start at 5V at a light load and output a decreasing voltage as load increases. The PSC1-005 provides the required signal conditioning and elevation compensation to implement the conversion. It provides sufficient range of adjustment to calibrate for the sensor conversion as well as performance modifications to the engine. It can be used with naturally aspirated or forced induction engines.

The PSC1-005 is one of a family of programmable calibrators. Other versions of the PSC1 are available that can do mapping where the primary axis is absolute or boost pressure. The PSC1-001 is designed to work specifically on MAP based fuel injection systems.

Through a serial interface, the PSC1-005 can be programmed by a laptop computer running the Split Second R4 software. The software provides three dimensional mapping of the MAF signal. The MAF value output is determined by the active cell value. The active cell is determined by MAF sensor output voltage and RPM.

The calibration of the PSC1 is done through a serial interface, which is active while in operation. The R4 software runs on Windows 95/98/NT/2000. The software provides real time display of RPM, manifold pressure, and cell value. The R4 software is the same software that is used to program the AIC1. A variety of editing tools ease the task of setting up an initial map and quickly fine tuning for optimum performance.

Features:

- Two three-dimensional map tables defined by MAF voltage and RPM
- Compatible with 2 and 4 stroke engines from 1 to 12 cylinders
- Laptop adjustable
- Elevation compensation
- Can be mounted in the engine compartment
- Transient surge and battery reversal protection

Recommended Connection:

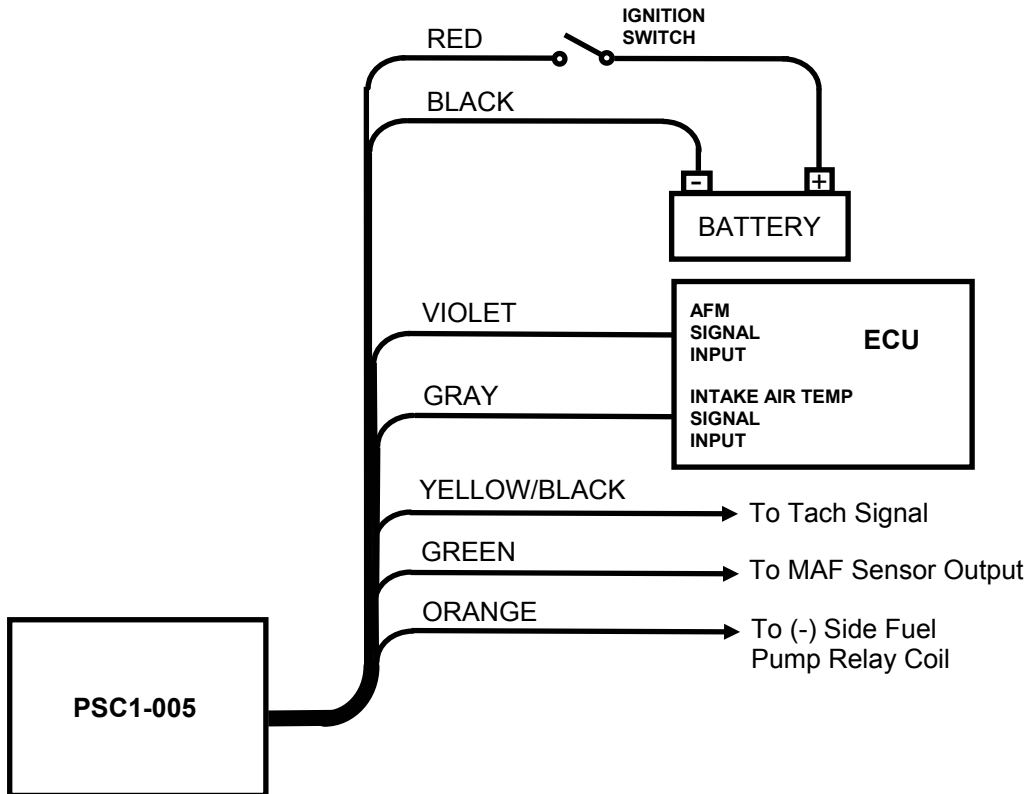

The PSC1-005 is used to condition the MAF sensor output to look like an air flow meter signal. The values in the map table A are used to offset the MAF signal output. The map values are used to both match the curve of the AFM signal and tune the engine for performance modifications.

A cell value of 10 leaves the signal unchanged. A cell value of 20 adds 2.5V to the signal. A cell value of 0 subtracts 2.5V from the signal. One significant digit is allowed to the right of the decimal point. Values such as 12.3 are permissible. There are a total of 200 cell values creating a resolution of 25mV.

Wire Assignments:

LABEL	CONNECT TO	WIRE COLOR
B+	Switched battery positive	Red
B-	Signal ground at ECU	Black
MAF IN	MAF sensor output	Green
SIGNAL OUT	ECU AFM input	Violet
TACH	Tach signal (pulses per rev = #cyl/2)	Yellow/Black
TEMP	ECU intake air temp input	Gray
Fuel Pump	Fuel pump relay coil – negative side	Orange
F-DB9	Serial connector on computer	-

Wiring Hints:

- 1) Connect the Black wire to the ECU sensor ground.
- 2) Connect the Red wire to a source of power that is switched by the ignition and maintains a solid battery voltage during cranking.
- 3) Be sure to connect the sensor ground of the MAF sensor to the ECU sensor ground.
- 4) Connect the Orange fuel pump relay driver to the negative side of the fuel pump relay. The other side of the relay coil should be tied to switched +12V.
- 5) The Gray wire can be used to provide the intake air temp signal. It will tell the ECU that it is a constant 70 degrees F. For better cold start performance, a separate air temp sensor may be used.

Software:

The PSC1 is programmed with the R4 Fuel Controller Software. Refer to the R4 data sheet for more information on programming. When the software is launched, an identification screen will appear that says Split Second. After four seconds, the main menu will appear. If this is a new application, select **File** then **New Customer** to create a new customer. Type in the customer name and save. The default location for customer names is My Documents. When you return to the main screen, select **File** and **Open Customer** to open the customer file that you just created. Once the customer is open, the **Maps**, **View**, **Options** and **Help** tabs become active. Whenever you write new data to the PSC1, all settings and mapping will automatically be saved under the current customer name. You can fill in the various fields such as name, address etc. if you like.

Connections:

Select the proper com port for the serial connector on your computer. Remove the lid on the PSC1. Connect the PSC1 to the computer using a 9-pin serial cable. The cable must have a male plug on one end and a female on the other. Once the serial cable is plugged in and the PSC1 is powered up, you may connect to the PSC1 by selecting the **Connect to ECU** icon. Once communication has been established with the ECU, the **Real Time** pull down becomes active.

Programming:

Use the **Options** pull down and **Systems Settings** option to select Voltage mode and Programmable Signal Conditioner. Use the **Options** pull down and **Engine Settings** to select the number of cylinders of the engine.. Use the **Maps** pull

down to access the fuel map tables. There are two map tables in the R4 program. The PSC1 uses table A. The active cell at any given time is determined by the MAF sensor reading and RPM.

The number entered into the cells on the map represent the amount that the input voltage is offset (signal modify mode). The number entered in the cell can range from 0.0 to 20.0. The step size is 25mV. Example outputs are shown on the following table. Note that there are 200 cell values. Only 20 are shown for simplicity.

Cell Value	Voltage Offset
0	-2.5
1	-2.25
2	-2.0
3	-1.75
4	-1.5
5	-1.25
6	-1.0
7	-0.75
8	-0.5
9	-0.25
10	0.0
11	0.25
12	0.5
13	0.75
14	1.0
15	1.25
16	1.50
17	1.75
18	2.0
19	2.25
20	2.5

You can click and drag to highlight an area of cells. Once highlighted, you can use the icons across the top of the window to fill all the selected cells with a value.

A highlighted area of cells can also be changed by a percentage by using the **Change By** button. To increase a highlighted area of cells by 10 percent for example, select the cells, click on the **Change By** button and enter 10. To reduce by 50 percent, enter -50.

You can also fill a range of cells with values that are interpolated from the end points. This works over a row, column or 2-dimensional area. To fill values over a two dimensional area, fill the four corners of the area with cell values. Then click and drag to select the area encompassed by those corner cells. Click on the **Auto Fill** button. The software will calculate and fill the correct values for all highlighted cells.

Once the maps are set up, you can write to the ECU in the PSC1. To write to the ECU, the ignition must be on so that the PSC1 is powered up. The engine must be off so that tach pulses are not present during programming. To write to the ECU press the **Write Data to the ECU** button. The operation of writing the data will also save the configuration and map information in the current file that is open. You can also upload from the ECU using the **Read Data from the ECU** button. You can then save or modify the data.

Operation:

Once the data is loaded into the PSC1, the engine can be started. From the main screen, the **Real Time** pull down can be used to observe a variety of operating parameters. The **All** option brings up a window that displays MAF voltage and RPM as well as cell value. The All window can be enlarged to full screen size to make it easy to read while working on the engine. The **RPM** and **Voltage** options display analog gauges that show those parameters. The **All**, **RPM** and **Pressure** options can all be displayed simultaneously.

Electrical Characteristics:

PARAMETER	CONDITIONS	MIN	TYP	MAX	UNITS
Supply Voltage	BATT+ to BATT-	12	13.5	15	V
Supply Current	Into BATT+ terminal		16		mA
Input Voltage range		0		5	V
Output Voltage range		0		5	V
Relay Driver	Maximum Output		-200		mA
Tach threshold	Normal operation		1.6		V
Tach Hysteresis	Normal operation		0.5		V
Output current	Steady state source current		10		mA

Mechanical Characteristics:

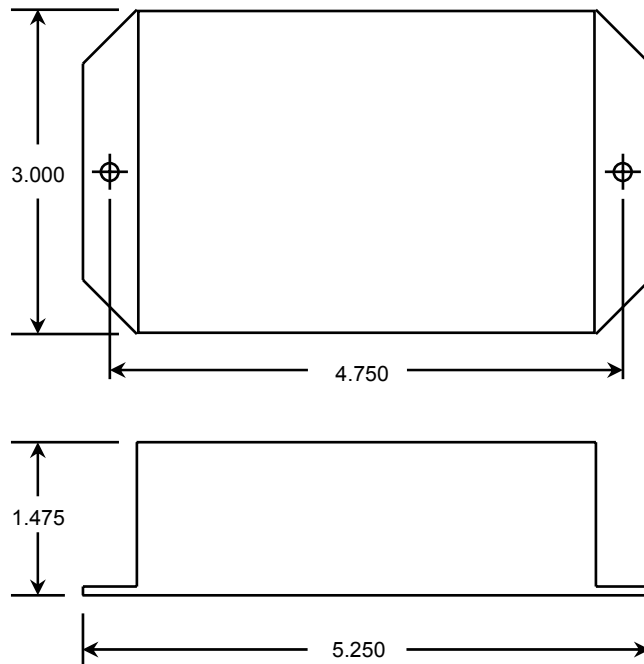

1949 E. Deere Ave.
 Santa Ana, CA 92705
 TEL (949) 863-1359
 FAX (949) 863-1363