



PSC1-002 Programmable Signal Calibrator

Description:

The PSC1-002 Programmable Signal Calibrator provides precise calibration of fuel by adjusting fuel control signals. It is designed specifically for 5V map sensor based engine management systems. It is used on engines that have been converted to forced induction. It has an internal 2 Bar MAP sensor that is used to replace the stock map sensor.

Through a serial interface, the PSC1-002 can be programmed by a laptop computer running the Split Second R4 software. The software provides three dimensional mapping of the MAP signal. The MAP value output is determined by the active cell value. The active cell is determined by absolute pressure measured by the internal sensor and RPM.

The calibration of the PSC1 is done through a serial interface, which is active while in operation. The R4 software runs on Windows 95/98/NT/2000. The software provides real time display of RPM, manifold pressure, and cell value. The R4 software is the same software that is used to program the AIC1. A variety of editing tools ease the task of setting up an initial map and quickly fine tuning for optimum performance.

Features:

- Operates as a programmable MAP sensor
- Two three-dimensional map tables defined by absolute pressure and RPM
- Compatible with 2 and 4 stroke engines from 1 to 12 cylinders
- Laptop adjustable
- Can be mounted in the engine compartment
- Internal MAP sensor
- Transient surge and battery reversal protection

Basic Connection – Programmable MAP Sensor:

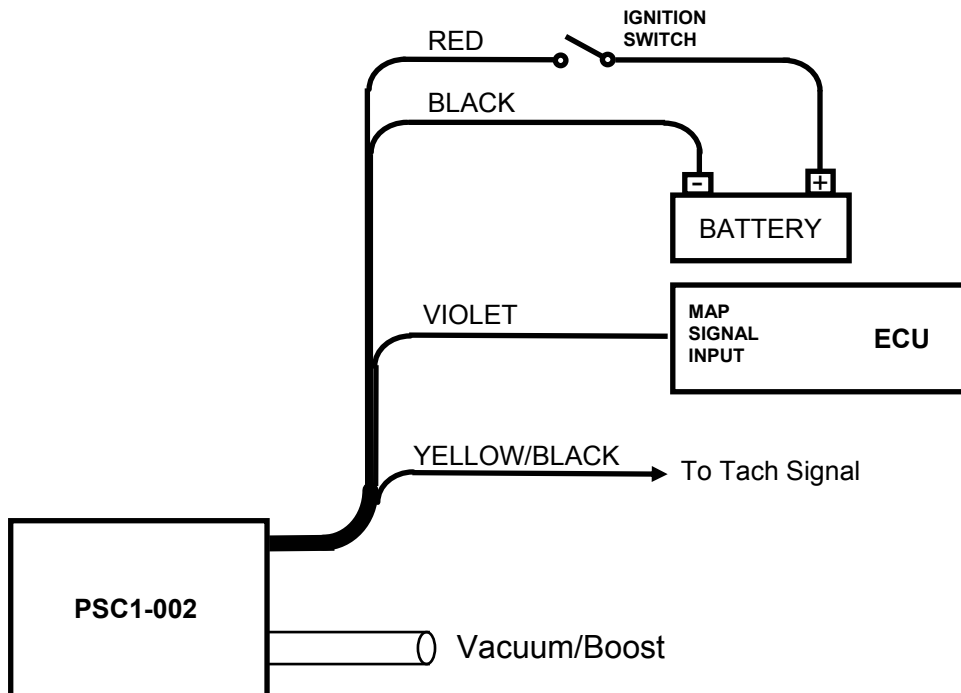

This is the typical connection for most engine management applications. In this mode, the Output to the ECU is a modified version of the internal MAP sensor signal. The internal map sensor varies from 0 to 5V as the pressure varies from a deep vacuum to 14.7 PSI of boost. The map table in the PSC1-002 is used to modify the MAP signal as necessary.

The range of adjustment is +/- 2.5V. A cell value of 0 will subtract 2.5V from the signal. A cell value of 10 will not alter the signal. A cell value of 2.5V will add 2.5V to the signal. The starting map for this configuration is a map loaded with 10 in every cell.

Wire Assignments:

LABEL	CONNECT TO	WIRE COLOR
B+	Switched battery positive (+12V)	Red
B-	Signal common	Black
MAP OUT	ECU MAP input (in signal modify mode)	Violet
TACH	Tach signal (pulses per rev = #cyl/2)	Yellow/Black
F-DB9	Serial connector on computer	-

Software:

The PSC1 is programmed with the R4 Fuel Controller Software. When the software is launched an identification screen will appear that says Split Second. After four seconds, the main menu will appear. If this is a new application, select **File** then **New Customer** to create a new customer. Type in the customer name and save. The default location for customer names is My Documents. When you return to the main screen, select **File** and **Open Customer** to open the customer file that you just created. Once the customer is open, the **Maps**, **View**, **Options** and **Help** tabs become active. Whenever you write new data to the PSC1, all settings and mapping will automatically be saved under the current customer name. You can fill in the various fields such as name, address etc. if you like.

Connections:

Select the proper com port for the serial connector on your computer. Remove the lid on the PSC1. Connect the PSC1 to the computer using a 9-pin serial cable. The cable must have a male plug on one end and a female on the other. Once the serial cable is plugged in and the PSC1 is powered up, you may connect to the PSC1 by selecting the **Connect to ECU** icon. Once communication has been established with the ECU, the **Real Time** pull down becomes active.

Programming:

Refer to the R4 data sheet for specific information on how to use the R4 software. Use the **Options** pull down and **Systems Settings** option to select Vacuum/Pressure mode and Programmable Signal Conditioner. Use the **Options** pull down and **Engine Settings** to select the number of cylinders of the engine. Use the **Maps** pull down to access the fuel map tables. There are two map tables in the R4 program. The PSC1 uses table A. The active cell at any given time is determined by the MAP sensor reading and RPM.

The PSC1-002 is calibrated to read throughout the vacuum region and up to 16 PSI of boost. In order to read the proper scale on the map tables and on the real time display, select options and system settings. From this screen, select Programmable Signal Calibrator and either Absolute pressure or Vacuum/Pressure.

The absolute scale reads in PSI. An absolute vacuum corresponds to 0 PSI, ambient pressure is 14.7 PSI and 16 PSI of boost reads as 30.7 PSI. The Vacuum/Pressure scale reads in inHg in the vacuum region and PSI in the boost region. An absolute vacuum would be -30 inHg, ambient pressure reads as 0

and 16 PSI of boost reads as 16 PSI. The vacuum and pressure readings are based on sea level conditions. As you move up in elevation and atmospheric pressure goes down, the ambient pressure reading will move down into the vacuum reading.

The number entered into the cells on the map represent the amount that the input voltage is offset (signal modify mode). The number entered in the cell can range from 0.0 to 20.0. The step size is 25mV. Example outputs are shown on the following table.

This table shows the output voltage change for different cell values. Note that there are 200 cell values. Only 20 are shown for simplicity.

Cell Value	Voltage Change
0	-2.5
1	-2.25
2	-2.0
3	-1.75
4	-1.5
5	-1.25
6	-1.0
7	-0.75
8	-0.5
9	-0.25
10	0.0
11	0.25
12	0.5
13	0.75
14	1.0
15	1.25
16	1.50
17	1.75
18	2.0
19	2.25
20	2.5

You can click and drag to highlight an area of cells. Once highlighted, you can use the icons across the top of the window to fill all the selected cells with a value. For example, in the direct mode, if you fill the selected cells with the value 10, whenever the manifold pressure and RPM match one of those cell locations, the output voltage will be 2.5V.

A highlighted area of cells can also be changed by a percentage by using the **Change By** button. To increase a highlighted area of cells by 10 percent for example, select the cells, click on the **Change By** button and enter 10. To reduce by 50 percent, enter -50.

You can also fill a range of cells with values that are interpolated from the end points. This works over a row, column or 2-dimensional area. To fill values over a two dimensional area, fill the four corners of the area with cell values. Then click and drag to select the area encompassed by those corner cells. Click on the **Auto Fill** button. The software will calculate and fill the correct values for all highlighted cells.

Once the maps are set up, you can write to the ECU in the PSC1. To write to the ECU, the ignition must be on so that the PSC1 is powered up. The engine must be off so that tach pulses are not present during programming. To write to the ECU press the **Write Data to the ECU** button. The operation of writing the data will also save the configuration and map information in the current file that is open. You can also upload from the ECU using the **Read Data From the ECU** button. You can then save or modify the data.

Operation:

Once the data is loaded into the PSC1, the engine can be started. From the main screen, the **Real Time** pull down can be used to observe a variety of operating parameters. The **All** option brings up a window that displays boost pressure and RPM as well as cell value and duty cycle for both A and B channels. The All window can be enlarged to full screen size to make it easy to read while working on the engine. The **RPM** and **Pressure** options display analog gauges that show those parameters. The **All**, **RPM** and **Pressure** options can all be displayed simultaneously.

Electrical Characteristics:

PARAMETER	CONDITIONS	MIN	TYP	MAX	UNITS
Supply Voltage	BATT+ to BATT-	12	13.5	15	V
Supply Current	Into BATT+ terminal		16		mA
Tach threshold	Normal operation		1.6		V
Tach Hysteresis	Normal operation		0.5		V
Vacuum/Boost	On vacuum/boost hose	0		2.5	Bar
MAP output	Steady state source current		0.1		mA
Direct Output	Steady state source current		10		mA
Modify Output	Steady state source current		10		mA

Mechanical Characteristics:

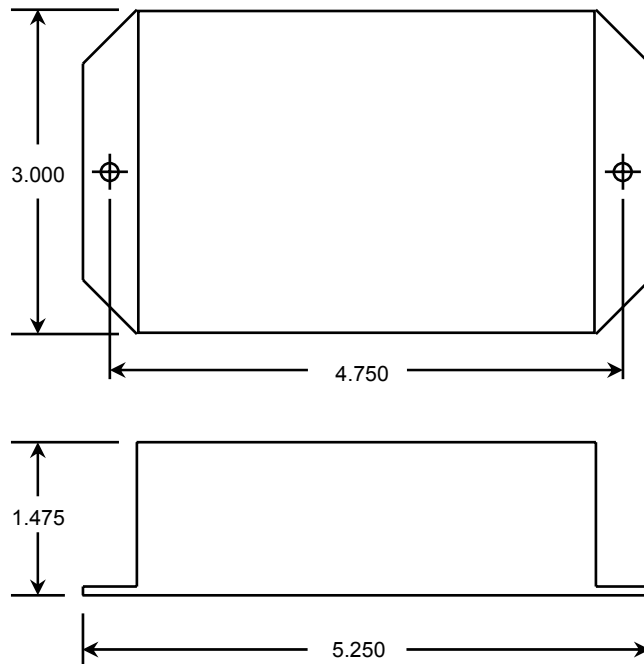

1949 E. Deere Ave.
 Santa Ana, CA 92705
 TEL (949) 863-1359
 FAX (949) 863-1363